

# Zentrischspanner Typ ZSM2-130

## Self-centering vices type ZSM2-130

### Zentrischspanner Typ ZSM2-130

#### Self-centering vice type ZSM2-130

- Für 4/5-Achs-Bearbeitung
- Wiederholgenauigkeit: 0,01 mm
- mit Niederzugeffekt

- for 4/5-axes machining
- repeatability: 0,01 mm
- with pull-down mechanism

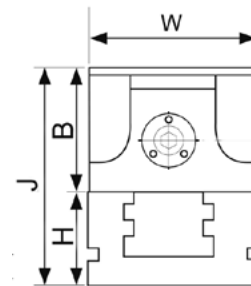
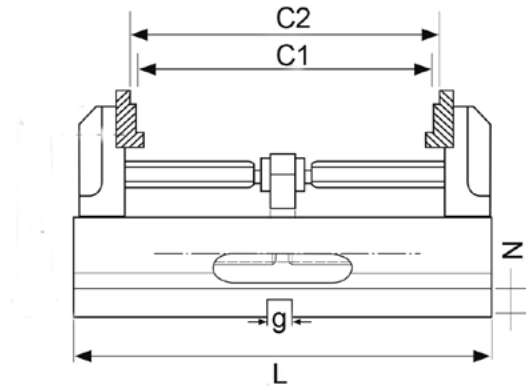
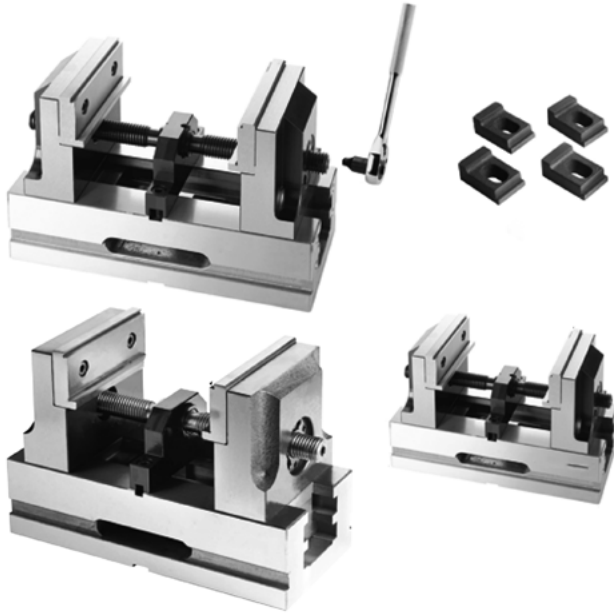

W mm	J mm	C1	C2	H mm	B mm	N mm	g mm	L mm	Spann- kraft / Clamping force daN	Anzugs- moment/ Torque Nm	kg	Art.-Nr./ Order no.	EUR
Spannweite / Clamping range													
131	200	17-180	25-188	80	120	21	16	290	1470	25	31,5	<a href="#">ZE-ZSM2-130</a>	1.579,80

Inkl. 4 Spannpratzen und Schlüssel  
Incl. 4 clamping brackets and key

